



EP0402013 Overhead – Ionizer with 5 fans

Use of the device

The ESD-Protect Overhead Ionizers Q133 is used to neutralize electrostatic fields and the charge in the room and over production lines, belt conveyors or work tables.



 WARNING
<ul style="list-style-type: none"> • If the equipment is used in a manner not specified by the manufacturer, the protection provided by the equipment may be impaired. • Do not let the water touch the product. It may cause electric shock or fire due to malfunction. • When you check or maintain the product, make it sure you turn off the power. It may cause electric shock or fire due to malfunction. • Secure the product firmly when you want to secure it. There is a possibility of accident due to fall-over or malfunction, etc. • Do not use the product at the place where dangerous material such as inflammable or ignitable material exists. This product is not the product of anti-explosive type. • This device is made only for industrial uses. You need to ground the device beforehand. Otherwise, there are in case of malfunction, electric shock, or fire damage.

 CAUTION
<ul style="list-style-type: none"> • Do not contact the discharge needle or terminal with power applied. There is a possibility of electric shock or malfunction. • Handle the discharge needle with care as its tip is very sharp. • Connect wires referring to the product manual. Wrong connection can cause failures. • Take precautions as cables of the adaptor, the power line and communication line of each product may disconnect. If the cable is damaged, replace it immediately. • Do not install the device where the vibration can be detected. Any min or impact or vibration on the device, the malfunction or danger of accident might happen. • Do not use the product for the purpose outside of the range of the product use. If the product is used for the purpose outside of the range of the use, it can result in the trouble or the shortened service life, or an unexpected problem may occur.

The following sketches and drawings apply mutatis mutandis to all Q133 ionizers. The 2-fan variant is mainly shown here.

Connections and functions

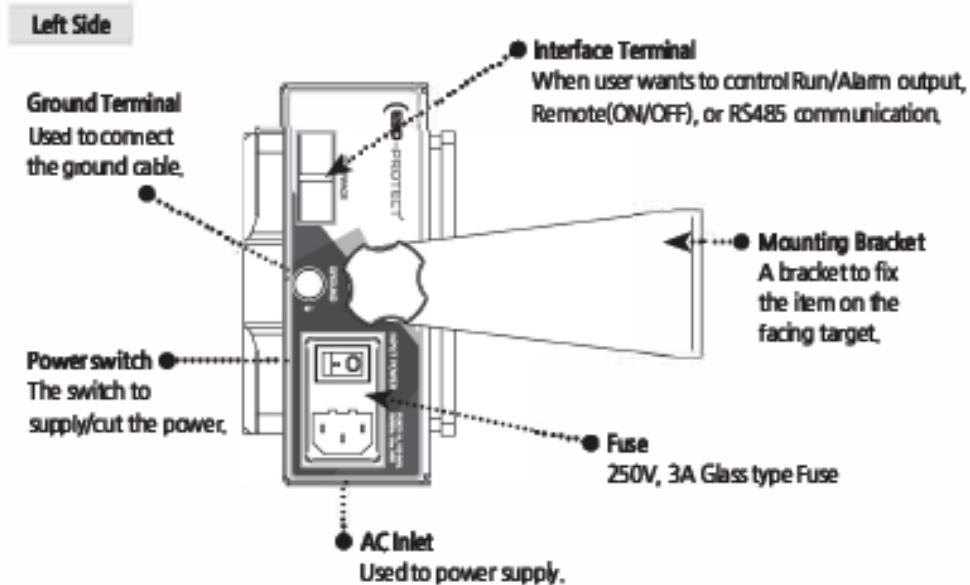
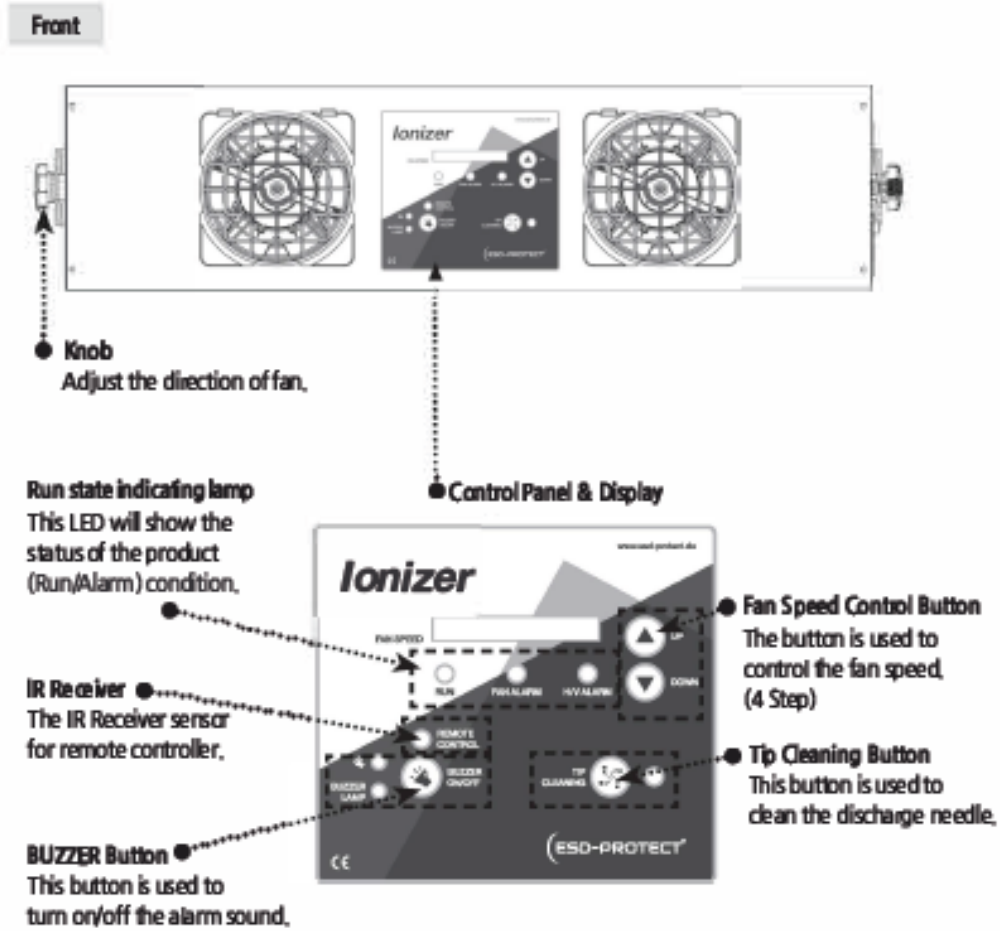

Scope of delivery

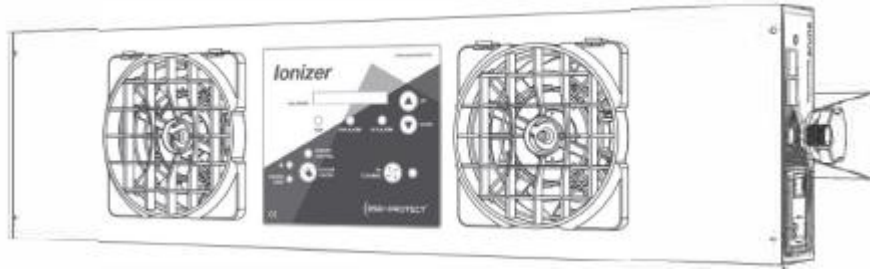

Power Cable
SPC-MT-1-001
AC 100V, 50/60Hz, 1.8m / 1ea
or
Power Cable
SPC-MT-2-001
AC 220V, 50/60Hz, 1.8m / 1ea



Ground Cable
SGC-MT-2-001
1m /Ø6-Ø4[mm] / 1ea

Options

If you need additional features, you'll need to add additional items for more Purchase assistants (see below).



RMS Controller
RMSU



Remote Controller
SBL-RC2



Signal Cable
SUC-MT-2-001
10m



UTP Cable
SUC-B3-1-001
10m

Installation

 WARNING
<ul style="list-style-type: none">• Please adjust the device in the proper position upon the area you install. The item should be laid on the flat surface.• When installing the device, please be aware of high temperature/humidity.• If there are any random objects that are closely surrounded or touched the target object, the ionizing performance might decrease. Please consider the area where you install.• The performance of device will decrease if the ground is insecurely connected. The proper ground connection is always a first thing to consider.

Installation instructions

- a. Determine the point where the device will be installed.
- b. Attach the Ionizer to the ceiling with the bracket with M6 screws or on the wall.
- c. Connect the ground wire to a ground terminal.
- d. Connect the UTP cable (option)
- e. Connect the power supply to the ionizer.
- f. Activate the ionizer via the power connector.
- g. Check the function of the lamp.
- h. Set a position in which the ionized air will reach its destination.

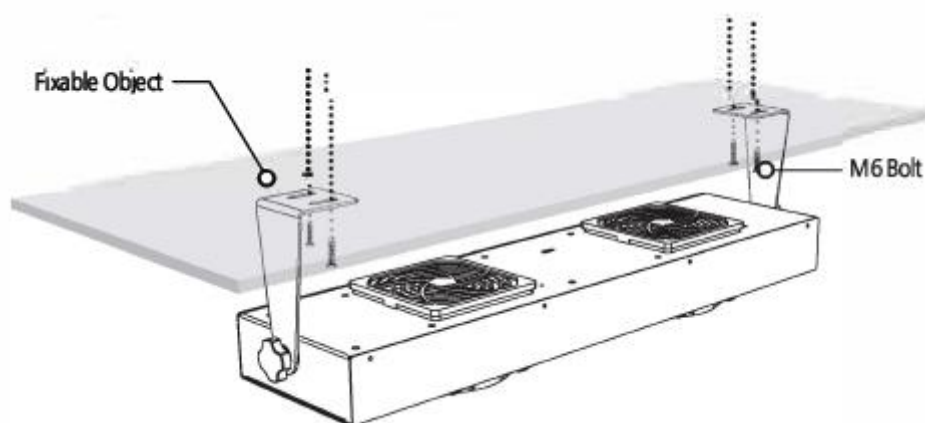

Connection

Refer to the image below to connect the product:

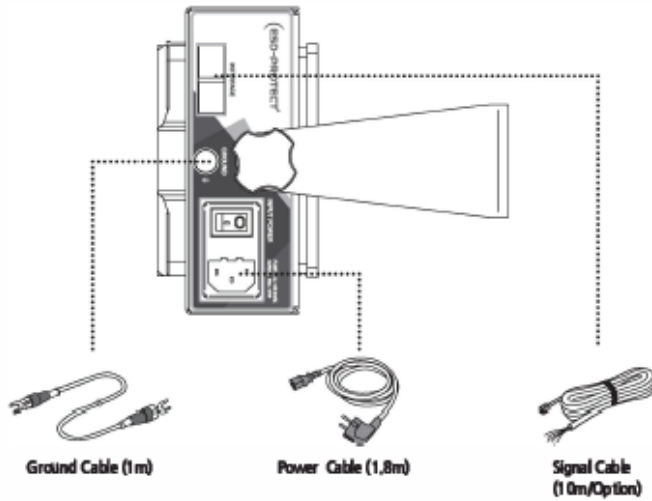

Be sure to ground the 50B-S series enclosure to ensure the stable performance of the product and avoid electric shock.

Connect the signal cable if you want to send a signal to the outside.

The input power of the power supply is AC 100-240V, 50-60Hz.

Connection of the interface (signal cable)

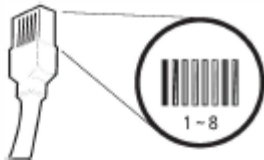

Nr	Farbe	Beschreibung	Bemerkungen
1	Braun	RS 485 +	RS 485 Kommunikation (Run, Stop, Tip Cleaning Signal)
2	Weiß & Braun	RS 485 -	
3	Orange	Ground	-
4	Weiß & Orange	Remote	If the #4 and #3 pins are short-circuited, the product stops operating
5	Grün	Tip Cleaning	The tip cleaning motor is rotated when #5 & #3 pins are closed more than one second
6	Weiß & Grün	Run State	When #6 & #8 pins are closed, SOB-S is working
7	Blau	Alarm (Ion Unbalance / Fan)	When #7 & #8 pins are closed, SOB-S is signaled alarm
8	Weiß & Blau	Common	-

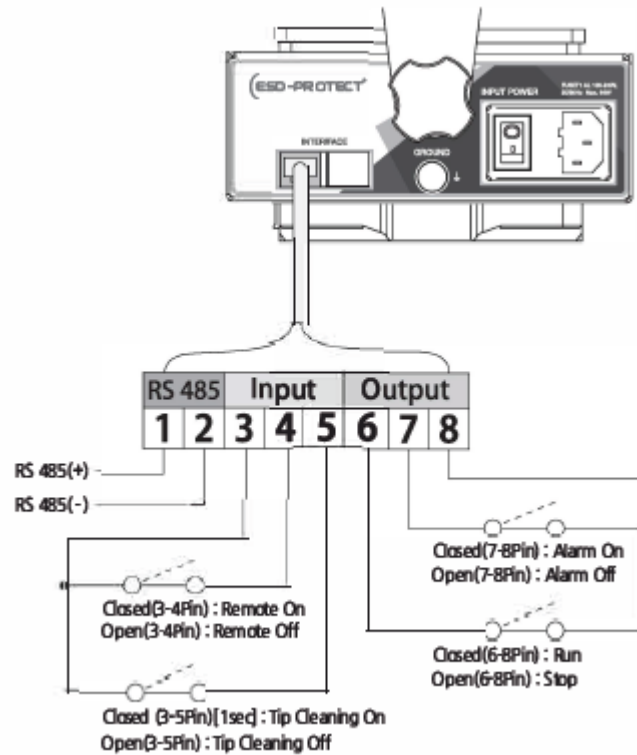

Outputs :

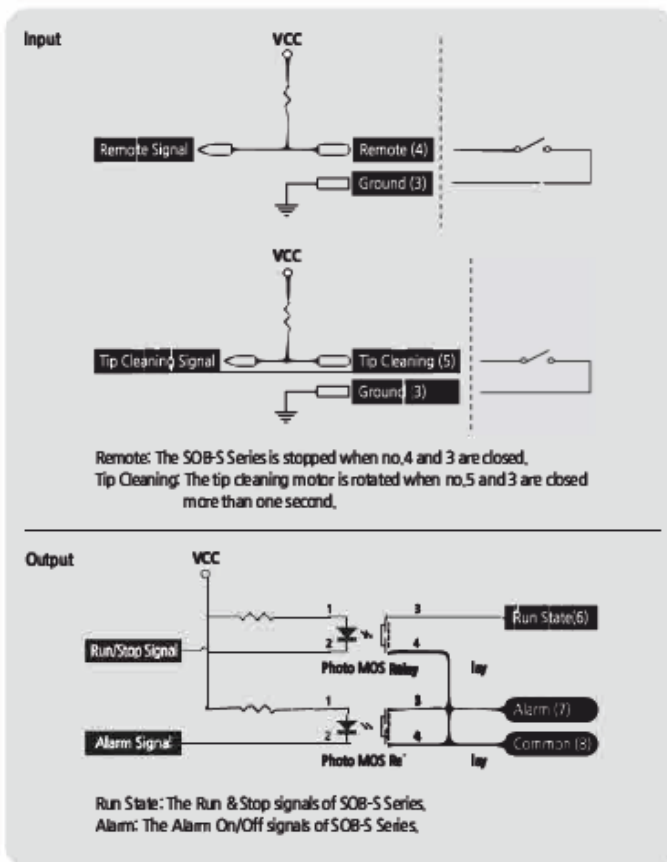

Connecting to a PC

It is possible to control the run/stop alarm and peak cleaning operation via a computer.

The connection to the computer is made via an RS-232/RS-485 converter.

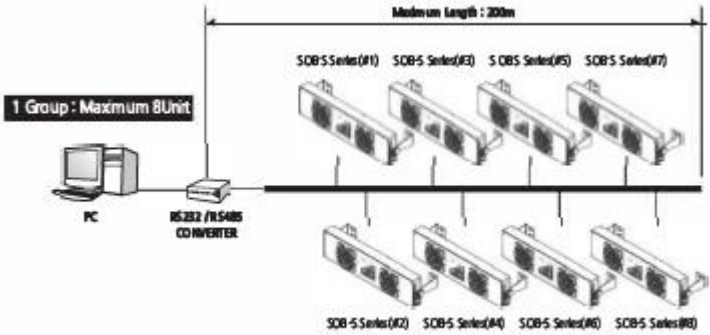

The method of connecting to the computer with multi-port

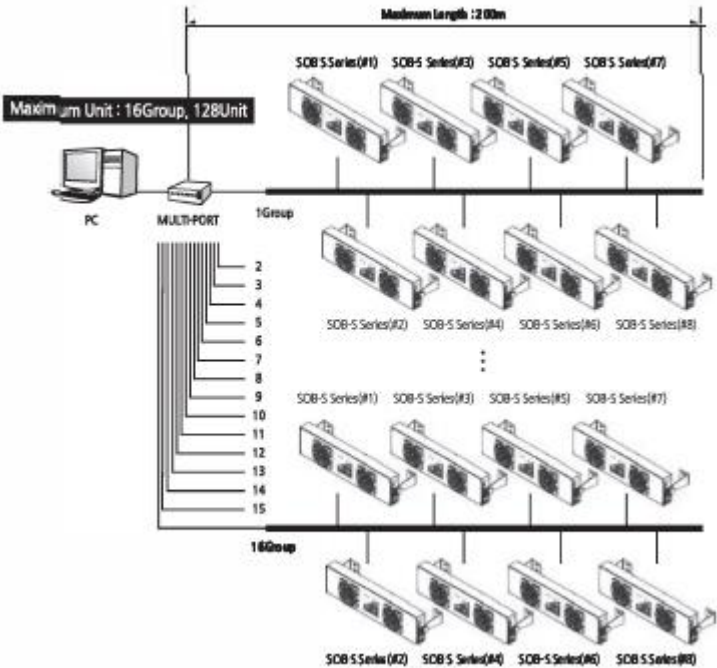

Setting the address

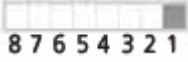
1. Wait 10 seconds after power on
2. You can access the address setting by pressing the Up/Down button at the same time.
3.  Depending on the number of LEDs that are lit, you can check the selected address.
4. You can set the address using the UP and DOWN buttons.
5. If there is no movement within 3 seconds, the selected address will be used and the setting mode will be exited.

Maintenance

Maintenance is an essential part of maintaining performance. Please perform routine maintenance according to the description below. The lifespan of a discharge needle can vary depending on the conditions of use. The SOB-S series requires regular maintenance and cleaning when used in adverse conditions (high humidity or dust). It is therefore recommended to clean the discharge needle regularly (at least once a month).

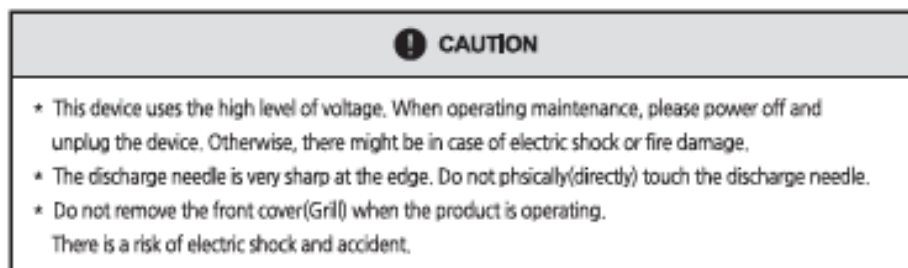

Cleaning of the emitter tip

The SOB-5 series has a brush for cleaning the needle. When the "Tip Cleaning" button on the front is pressed, the SOB-5 series will automatically clean the needle for 5 seconds when the fan stops operating.

Automatic cleaning

If the power-on status of the SOB-5 series lasts longer than 24 hours, the needle will be automatically cleaned every 24 hours. The cleaning of the emitter needle is carried out for 3 seconds before stopping the operation of the blower.

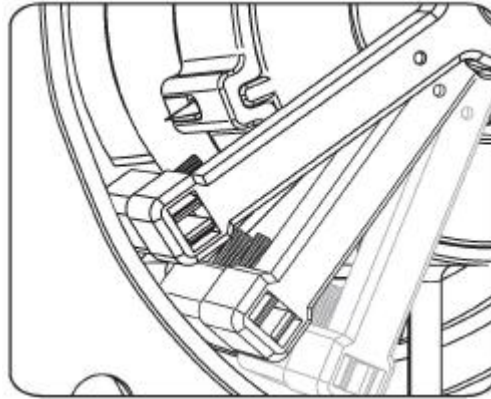

Manual cleaning

Manually clean the emitter needle if it is very dirty.

- a. Turn off the ionizer before cleaning it.
- b. Please open the front cover of the SOB-5 series.
- c. Dab the cotton swab with alcohol. (Do not use acetone)
- d. Place the cotton swab on the needle and wipe it by dragging the swab after Rotate right and left. (Be careful not to apply a strong force to the needle)
- e. Replace the damaged needle.
- f. After cleaning, leave the alcohol applied to the surface of the needle completely and then put the SOB-S series into operation.
- g. Please record the cleaning process for reference.

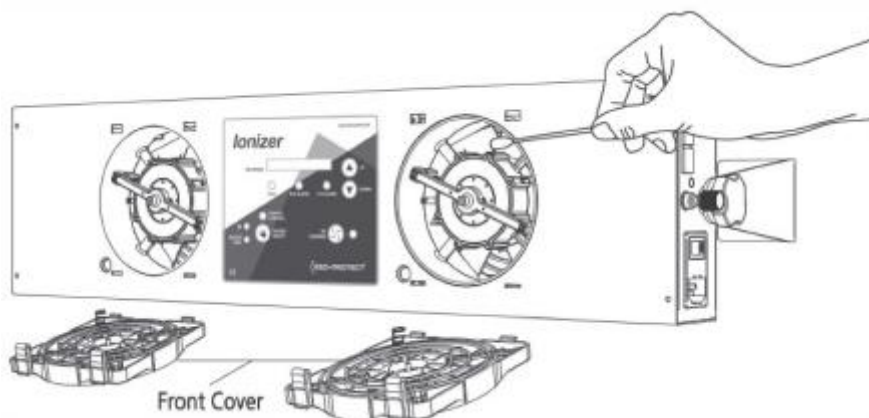

Discharge needle replacement cycle for current pickup

During cleaning, check the emitter needle and take action.

- a. Replace the broken or badly damaged discharge needle.
- b. You can replace the discharge needle directly with a long wrench. When replacing it, be careful not to damage the corner of the needle, otherwise it can easily break.
- c. The outlet needle is very sharp at the edge. Do not touch the outlet needle (directly).
- d. The general cycle for replacing the needle is one year, but it may vary depending on the environment of use.

Cleaning the fan filter

- a. Be sure to turn off the ionizer before cleaning.
- b. Wash the filter under running water.
- c. Dry the filter completely and insert it into the fan cover.
- d. If the filter is badly damaged, replace it.

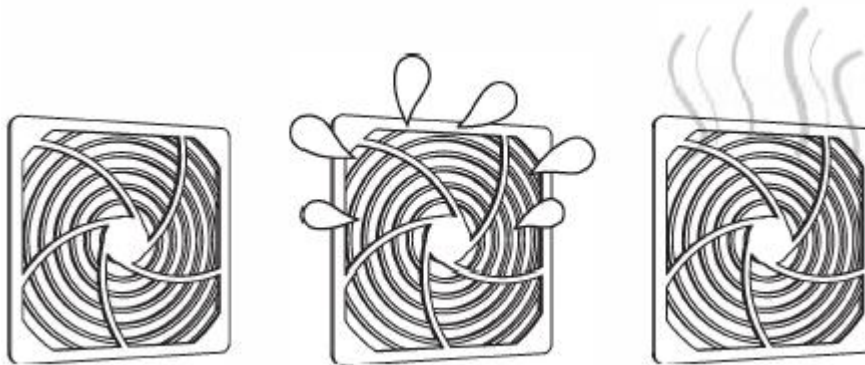

Problem solving

Pre-call checklist :

Problem	Identifying Problem	Solution
The product does not work.	Is your power cable still plugged in?	Please re-plug the power cable and then turn the device on again.
	Was the proper voltage level applied for this set-up?	Please use the proper level of power input for the device, (AC 100-240V, 50/60Hz)
	Is the switch OFF at left side of the device?	Turn ON the power switch.
There is no ionization.	Is there any conductive material around the device?	Please refer to 'Installation & Connection,' for setting the proper target distance from the device.
	Does the installed environment have too high/low level of humidity or temperature?	Please install the device upon the proper working specification.
The ionizing performance has been decreased.	Can't possibly ground the device?	Please refer to 'Installation & Connection,' for (proper) grounding the device.
	Any damages or cut on the cables?	You need to replace the cables if it gets cut or damaged.
	Any contamination on the discharge needle?	Please refer to 'Maintenance,' for cleaning the discharge needle.

Dimensions :

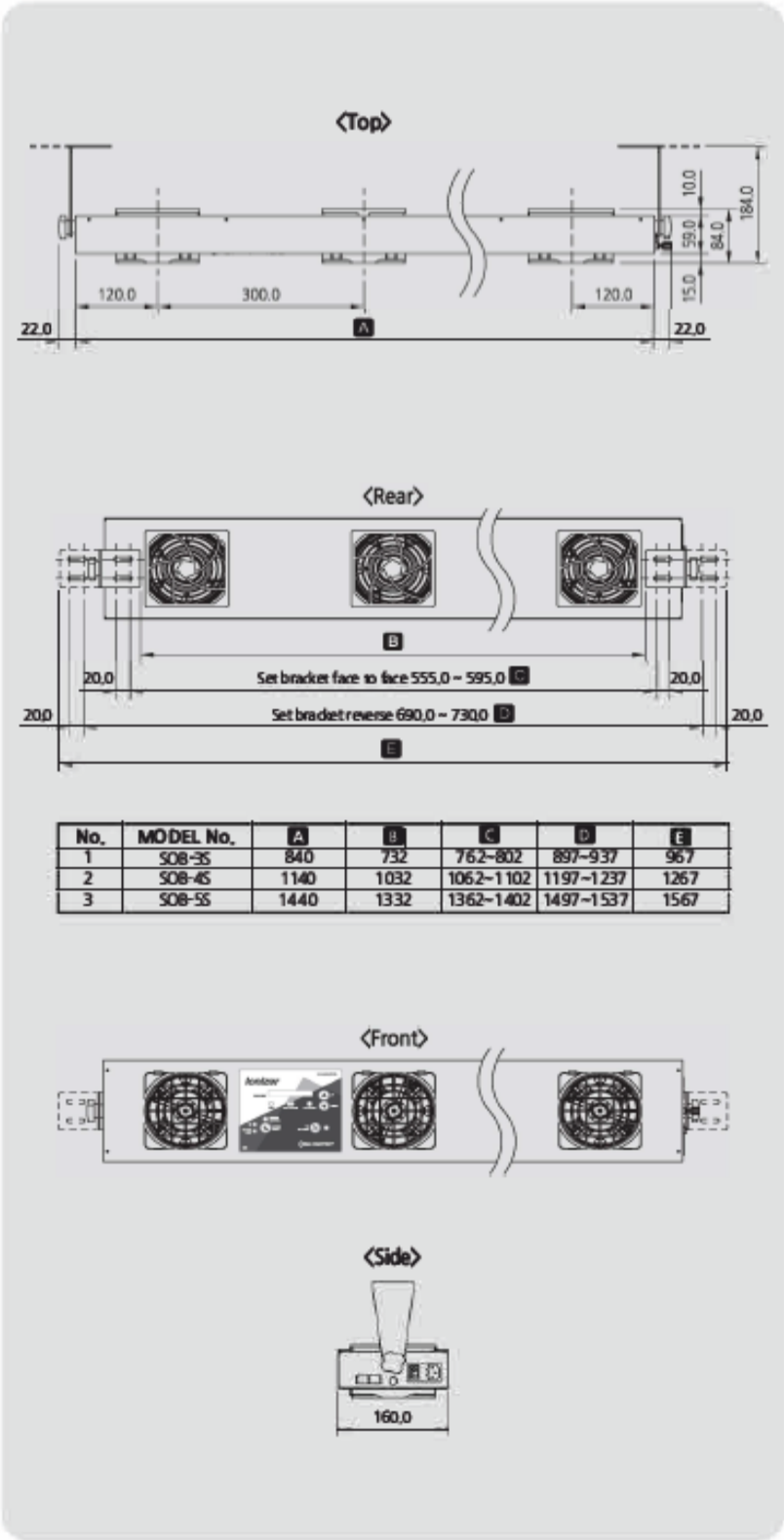

Technische Daten

POWER INPUT	AC 100~240V, 50/60Hz
ION GENERATION METHOD	Stationary direct current
POWER CONSUMPTION	75W
ELECTRICITY CONSUMPTION	341 mA
AIRFLOW	21.25 m ³ /min
NOISE LEVEL(DB)	67 dB
ION BALANCE	Within ±2V in 600mm, maximum airflow
OZONKONZENTRATION	0.05ppm
CIRCUMSTANCES OF THE OPERATION	0°C ~ +50°C, 35% ~ 85% RH
WEIGHT	6.2Kg
MATERIAL	Aluminium
MATERIAL ELECTRODE	Tungsten
ASSEMBLY	Ceiling and wall mounting
FUNCTION	4-stage fan speed, peak cleaning, automatic tip cleaning
ALARM FUNCTION	Ion alarm, alarm of blower
INTERFACE	Remote Control On/Off, Operating Status, Alarm, Peak Cleaning, RS 485
MAINTENANCE	1 year
DIMENSIONS	1477 x 84 x 160 mm (B x H x T)

* The appearance and specifications of the product may be changed by the manufacturer without prior notice in order to improve the product.